



BRIEF INFORMATION

Dual-glass mirrors for agricultural and construction machinery

- Standardised mirror, manually adjustable or electrically heated and electrically adjustable (12 V)
- Main and wide angle mirror in one housing
- Housing made of PP material
- Glass with optimised size according to ISO 5721-2 and ECE R46
- Side-specific positioning of wide-angle segment, increasing and optimising FOV

APPLICATION

The mirror is suitable for a variety of vehicles, including construction machinery, tele-handlers, front loaders, tractors, sprayers, combine harvesters and other special vehicles. The target groups for this product are the segments OE, SOE and Aftermarket.

It is very versatile and offers a convincing solution for the increasing demands of everyday worklife on construction sites as well as farms.

CUSTOMER BENEFITS

This dual-glass mirror provides greater safety in everyday work and traffic for the driver. The mirror has a maximised curvature with a glass radius of 1,260 or 310 mm, which is fully utilised to increase the driver's indirect field of vision. Due to the smart and compact design, it reduces at the same time the obstruction of the driver's direct view on traffic or work situations. No metal components are used to avoid the risk of corrosion, minimise weight and offer an attractive price.

TECHNICAL DETAILS

Technical Data

Operating Voltage	12 V
Mounting	Vertical and horizontal, manually or electrically adjustable
Support rod	Ø 18 to 24 mm
Housing	PP-housing with high UV-stability
Size	424 x 191 mm
Curvature radius of main mirror glass	1,260 mm
Curvature radius of wide angle lens	310 mm
Assembly	Pre-assembled screws for easy assembly

Dimensional sketch

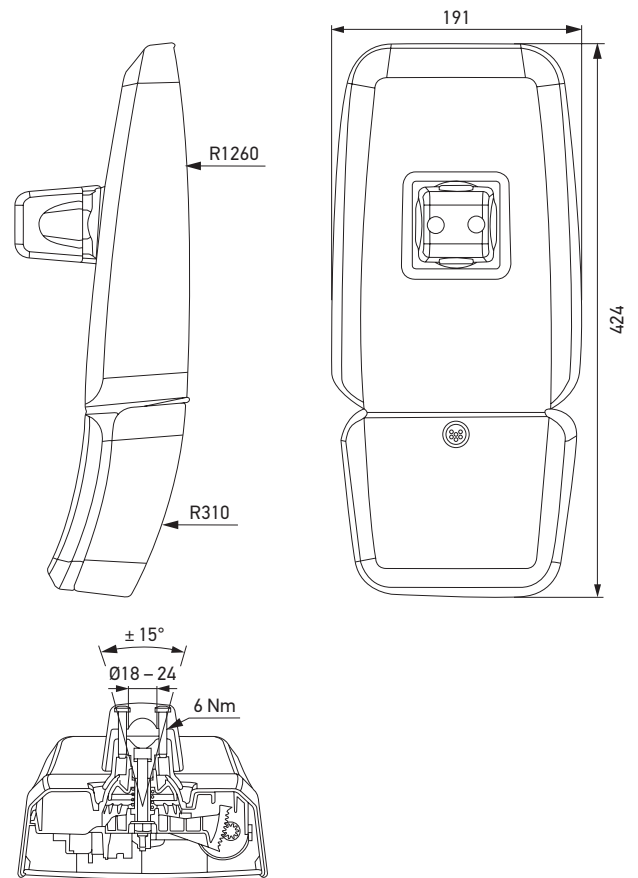

RANGE OVERVIEW

Product picture	Description	Heated	Adjustable	Part number
	Outside mirror	-	Manual	8SB 015 039-041 / -047 (right) 8SB 015 039-051 / -057 (left)
		X	Electric, 12 V	8SB 015 039-061 / -067 (right) 8SB 015 039-071 / -077 (left)