



SHIFTEC

Type 'X'



## DESCRIPTION

The Type 'X' mount from **Defence Dynamics** employs two or more leaf springs used in opposing pairs to form an elliptical leaf spring assembly. The spaces between the leaves are filled with a specially developed damping compound.

There are eight standard sizes of 'X' mount giving a load range of between 9 and 550 kg. These sizes are divided into three sub-groups based on their dimensions, with groups one and two being 51 mm (2") wide and group three being 102 mm (4") wide: 10 and 20; 45 70 110; 180 320 450.

The standard range has been augmented to provide a wider load range and different options based upon the physical size of the mounts

## APPLICATION

Approved by the MoD for Naval use these mounts were designed and developed primarily to protect delicate electronic equipment against shock. They are also used in submarines for suspension and elimination of noise in confined spaces. In addition, they are used in engineering applications throughout industry, giving protection against starting torques, overload surges etc.

The 'X' mount provides a space efficient shock mount design, which has unrivalled levels of damping. It also provides vibration isolation, not normally a feature of other shock mounts.

## INSTALLATION

The Type 'X' mount can be installed in any orientation allowing equipment to be mounted to the deck, bulkhead, or deck head. Combinations can also be used where equipment geometry requires it e.g. equipment mounted to the deck and to the bulkhead.

The 'X' mount uses a simple single bolt fixing method on each side of the mount which facilitates the installation of the equipment on board ship.



**SHIFTEC**

**Type 'X'**

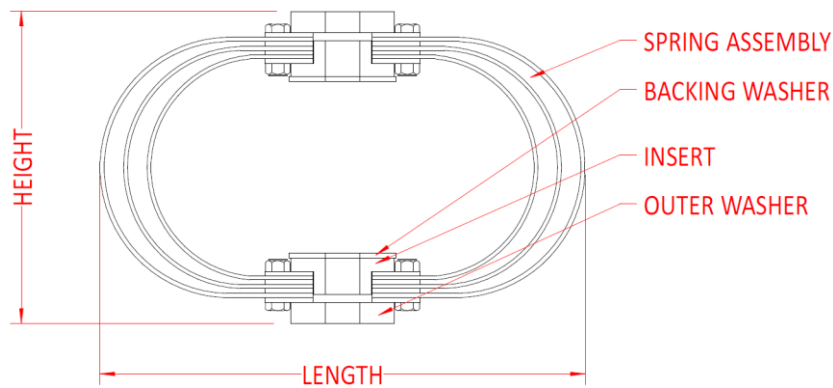

Part Number	NATO Stock Number	Nominal Rating	Supported Mass Range	Dimensions, mm					Approx. weight
				Height Loaded	Height Unloaded	Length	Width	Bolt Clearance	
			kg						kg
14/900U	5340-99-923-5717	10	9 – 18	107	114	203	51	M8	0.68
14/901U	5340-99-923-5718	20	13 – 35	106	114	203	51	M8	0.8
14/902U	5340-99-923-5719	45	35 – 55	124	133	216	51	M12	1.02
14/903U	5340-99-923-5720	70	55 – 90	124	133	216	51	M12	1.13
14/904U	5340-99-923-5721	110	90 – 135	122	133	216	51	M12	1.25
14/905U	5340-99-520-8429	180	135 – 250	185	190	297	102	M20	5.9
14/906U	5340-99-520-8428	320	250 – 380	186	190	297	102	M20	6.58
14/907U	5340-99-520-8427	450	380 - 550	184	190	297	102	M20	7.26
14/899U	5340-99-665-3921	6 A	3 – 6	73	82	134	25	M8	0.13
14/897U	Not allocated	6 B	3 – 6	75	82	134	25	M8	0.13
14/898U	5340-99-335-1954	6 S	5.4 – 10.8	107	114	203	30	M8	0.45
14/909U	5340-99-591-2587	150	135 - 175	122	134	216	51	M12	1.25

Rating	Dimensions, mm			
	A	B	C	D
kg				
6A, 6B	20	6	14.8	8.5
6S, 10, 20	31.8	9.5	21.5, 21.5, 22.5	9
45, 70, 110, 150	31.8	9.5	23.8, 24.8, 26.2, 26.8	13
180, 320, 450	63.5	12.7	39, 41, 43	21

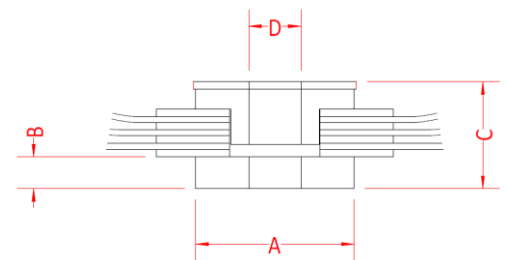

**DEFENCE DYNAMICS**

[shiftec.com](http://shiftec.com)

Neachells Lane, Willenhall, West Midlands, WV13 3SN, United Kingdom

T: +44 (0) 1902 308 000

E: [sales.dd@shiftec.com](mailto:sales.dd@shiftec.com)

MEMBER OF



While care has been taken to ensure that the information contained in this publication is accurate, we do not accept responsibility or liability for information which is found to be misleading. Specifications can change without notice.