



BRIEF INFORMATION

LED auxiliary indicator category 6, 2BM 011 788-...

- Attractive design – no visible external attachment.
- For horizontal surface mounting.
- In 12 V and 24 V.
- Can be used with or without frame.
- Customised frame styles available on request.
- 1:1 replacement of bulb variants 2BM 006 692 and 2BM 008 355 with framed variants possible.

PRODUCT FEATURES

Attractive design

The LED auxiliary indicator category 6 builds on the commercially established bulb variants (2BM 006 692 and 2BM 008 355). It features a modern and brilliant appearance as well as up-to-date LED technology.

Product variants

In addition to 12 V and 24 V variants, self-adhering and framed variants of this slim design light are available.

The self-adhering variant can be attached quickly and securely.

The framed version enables 1:1 replacement of bulb variants 2BM 006 692 and 2BM 008 355. The pocket and screws are covered with the frame.

On request, the shape of the frame can be modified and adapted to customer specifications.

PRODUCT FEATURES

Reverse polarity protection

If the contact to the pole is accidentally reversed, the light does not suffer any damage.

Contacts

A 2-pole AMP Superseal or a 500 mm sealed cable without a male connector housing may be selected.

Sealed to withstand high-pressure cleaning

Tested to IP 6K9, this light is protected from dust and water ingress under constant immersion.

High vibration resistance

The lights have been tested to HELLA Norm 67101 class 6.1 and meet the requirements for large-scale production buses, commercial vehicles, HGVs and tractors over 6.5 t.

Long design life

The latest LED technology provides an optimum signal pattern with low power consumption.

LED LIGHTING TECHNOLOGY

As a leading innovator in the field of automotive original equipment, HELLA is setting benchmarks:

Extremely low energy consumption

With the combination of efficient light-emitting diodes (LEDs) and precision optics, HELLA lights achieve the statutory light distribution with up to 83 % less power consumption compared to bulbs! No change of light source, no maintenance and an extremely long operating life thanks to optimal thermal management. To extend the design life of the light, the components are arranged in a way that optimises the temperature conditions, preventing overheating of the LEDs at extremely high temperatures. This thermal management maximises design life. The design life of the LEDs corresponds to that of the vehicle, depending on the operating temperature.

INSTALLATION

The framed variant



The framed version of the auxiliary indicator comprises a frame and light module. The two-part assembly kit enables 1:1 replacement of bulb variants 2BM 006 692 and 2BM 008 355.

First attach the light module to the designated position on the auxiliary indicator and then contact the light using a cable or AMP Superseal connector. The frame is equipped with a click system and can be securely engaged with the light module by applying light pressure.

The frame covers the pocket on the vehicle and the attachment screws.

The self-adhering variant



It features an adhesive strip and is attached by pressing on to the vehicle.

TECHNICAL DETAILS

Technical specifications

Type approval	ECE
Operating voltage	12 V and 24 V
Function	Auxiliary indicator category 6
Number of LEDs	7
Power consumption	4.8 W for 12 V and 3.5 W for 24 V
Operating temperature	-40°C to +65°C
Protection class	IP 6K9
Contacts	2-pole AMP Superseal connector (mating connector 8JA 746 184-022*) or 500 m cable with exposed cable end
Installation	Direct screw coupling with 3 screws \varnothing 4 mm** or self-adhering
Specification	HELLA Norm 67101 6.1
Design life	Design life of the vehicle***

* AMP 282080-1

** Not included

*** Dependent upon the operating temperature

Technical drawing

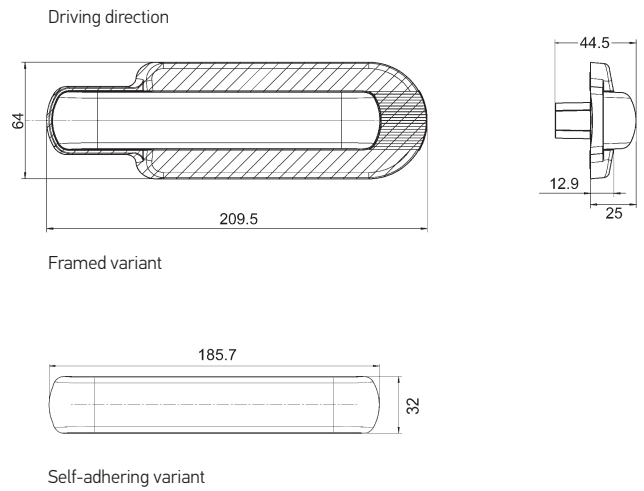

Hole pattern

Hole pattern for variant: 011 788-00/-01

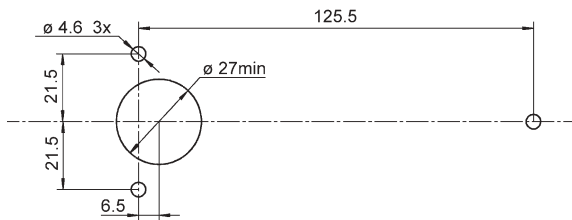

Hole pattern for variant: 011 788-04/-05

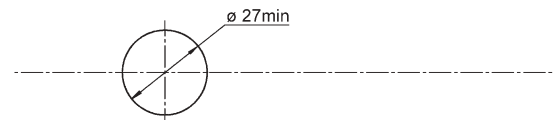

Hole pattern for variant: 011 788-02/-03

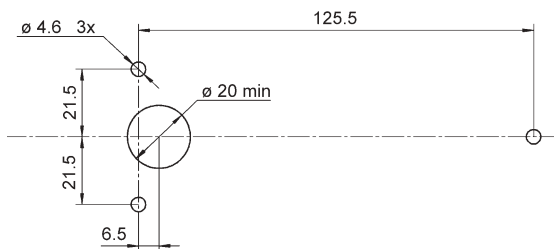

Hole pattern for variant: 011 788-06/-07

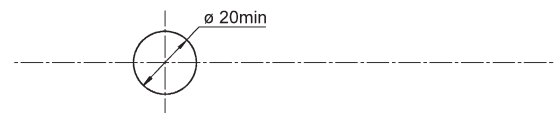

APPLICATION EXAMPLES



RANGE OVERVIEW

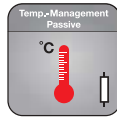
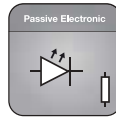

Description	Part number	PU
Direct screw coupling AMP Superseal with black frame	2BM 011 788-011/-017	1/50
Direct screw coupling 500 mm cable, exposed cable end with black frame	2BM 011 788-031/-037	1/50
Self-adhering AMP Superseal	2BM 011 788-051/-057	1/50
Self-adhering 500 mm cable, exposed cable end	2BM 011 788-071/-077	1/50

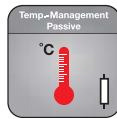
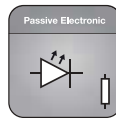

Description	Part number	PU
Direct screw coupling AMP Superseal with black frame	2BM 011 788-001/-007	1/50
Direct screw coupling 500 mm cable, exposed cable end with black frame	2BM 011 788-021/-027	1/50
Self-adhering AMP Superseal	2BM 011 788-041/-047	1/50
Self-adhering 500 mm cable, exposed cable end	2BM 011 788-061/-067	1/50

Spare parts / accessories	Part number
Black frame for part numbers 2BM 011 788-001/-007/-011/-017/-021/-027/-031/-037	9AB 194 559-007
AMP Superseal mating connector (AMP no. 282080-1)	8JA 746 184-022