



BRIEF INFORMATION

FL Mini

PRODUCT FEATURES

- Flashing light function
- High warning effectiveness
- UL approval
- SAE J845 class 3 approval

The FL Mini is a new, compact flashing LED beacon. LEDs are maintenance-free, they do not cause any additional costs for spare parts or maintenance. Downtime is reduced to a minimum.



Flashing light function



Polarity reversal protection – fully protects electronics, even if connecting leads are swapped round



IP X9K – resistant to high-pressure cleaners – protection against water during high-pressure cleaning



IP 67 – dust-tight, protected against temporary immersion in water

TECHNICAL DETAILS

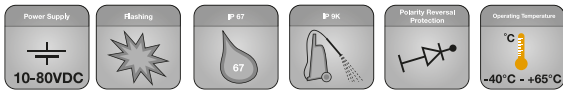

Technical Data

Rated voltage	multivoltage
Operating voltage	10 – 80V
Operating temperature	- 40°C to + 65 °C
Operating position	upright
Max power consumption	8 W
Protection class	IP 67, IP 9K
Inverse polarity protection	yes
Lens	impact resistant polycarbonate
Approvals	SAE J845 Class 3, UL-approval

Dimensional Sketch

FL Mini

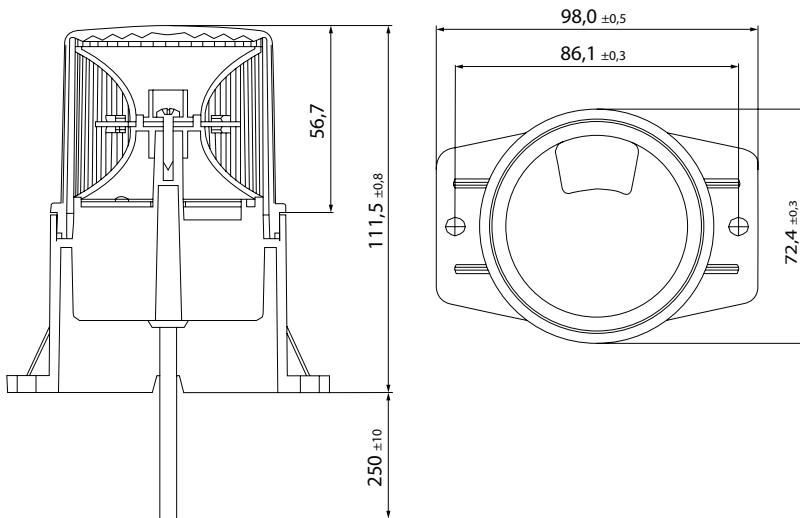

Range Overview

Product Photo	Target Groups	Part Number	Description	Operating Voltage
		2XD 014 959-111	FL Mini, amber	10-80V