



## BRIEF INFORMATION

### Warning light BST-Round

- Set of two BST-Round flashers and one controller
- Various flashing patterns
- Day / night mode included
- Can be synchronized with multiple units
- Clear or dark lens and different signal colours

### PRODUCT FEATURES

The BST-Round warning light is characterised by its new round design, which allows flexible installation in different areas of the vehicle. Four power LEDs and high-quality precision optics generate an intensive warning signal with minimum power consumption.

The warning lights are supplied as a set consisting of a controller, two flasherheads and two mounting rings. The power supply cable has an open end and the mounting rings as well as the mounting brackets allow easy and flexible installation. Due to the high-quality aluminium housing, the warning light is extremely temperature resistant. It can be used at  $-40^{\circ}\text{C}$  to  $+80^{\circ}\text{C}$ . The warning lights have different flash patterns, e.g. single flash or double flash. Further details on the different flash sequences can be found in the assembly instructions. In addition, the BST round warning lights are ECE-R65 and SAE homologated.



The BST-Round warning lights are supplied as a pre-configured set.



### Clear lens

The round warning lights are equipped with a clear lens as standard and the use of coloured LEDs allows different signal colours. All available product variants with clear lenses are listed in the product overview.

### Dark lens

The warning light BST-Round is also available with a dark lens on request. This variant is also supplied as a pre-configured set and generates a blue warning signal. Since the warning light with dark lens is inconspicuous and not immediately recognisable, it is particularly suitable for concealed use.

## TECHNICAL DETAILS

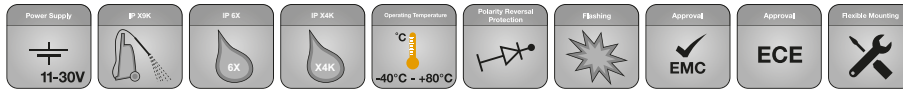

### Technical data





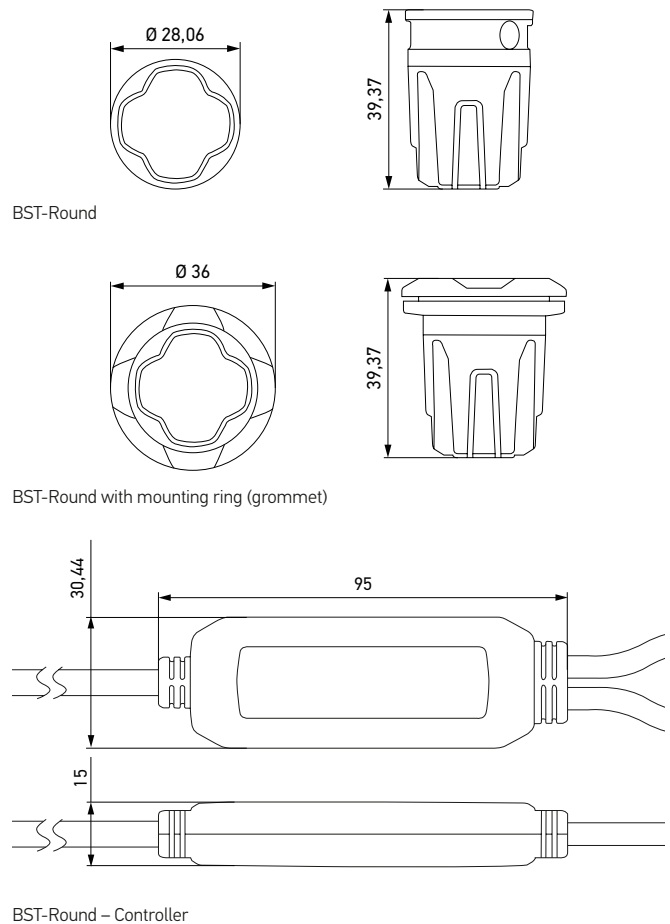



Rated voltage	Multi-voltage				
Operating voltage	11 – 30 V				
Power consumption	2,27 – 2,75 A (12 V)* 1,27 – 1,37 A (24 V)*				
Current consumption	27 – 33 W*				
Housing	Aluminium				
Connection	Cable length: 180 mm from light head to connector, 790 mm from light head to controller, 1,850 mm from controller to power supply open end				
Light source	LED				
Weight	100 g				
Temperature range	-40°C +80°C				
Polarity reversal protection	Yes				
Protection class	Lighthouse: IP 6X, IP X4K, IP X9K Controller: IP X7				
EMC protection	ECE-R10, CISPR 25 Class 3				
Lighting technology homologation	ECE-R10, ECE-R65, SAE J845 Class 1				
Homologation, amber	XA1 <table border="1"><tr><td>R10</td><td>051047</td></tr><tr><td>R65</td><td>000325</td></tr></table>	R10	051047	R65	000325
R10	051047				
R65	000325				
Homologation, blue	XB2 <table border="1"><tr><td>R10</td><td>051047</td></tr><tr><td>R65</td><td>000326</td></tr></table>	R10	051047	R65	000326
R10	051047				
R65	000326				
Homologation, red	XR2 <table border="1"><tr><td>R10</td><td>051047</td></tr><tr><td>R65</td><td>000329</td></tr></table>	R10	051047	R65	000329
R10	051047				
R65	000329				
Homologation, white	<table border="1"><tr><td>R10</td><td>51047</td></tr></table>	R10	51047		
R10	51047				

### Technical drawing



\* The product is still under development, data might differ.

## RANGE OVERVIEW

Product Image	Description	Approval	Lens	Warning Signal	Part number
	BST-Round, 1 controller, 2 flasherheads, 2 grommets	ECE	Clear	Blue	2XD 014 564-001
	BST-Round, 1 controller, 2 flasherheads, 2 grommets	SAE	Clear	Blue	2XD 014 564-101
	BST-Round, 1 controller, 2 flasherheads, 2 grommets	ECE	Clear	Amber	2XD 014 564-211*
	BST-Round, 1 controller, 2 flasherheads, 2 grommets	SAE	Clear	Amber	2XD 014 564-401
	BST-Round, 1 controller, 2 flasherheads, 2 grommets	ECE	Clear	Red	2XD 014 564-601
	BST-Round, 1 controller, 2 flasherheads, 2 grommets	SAE	Clear	Red	2XD 014 564-701
	BST-Round, 1 controller, 2 flasherheads, 2 grommets, SAE only	SAE	Clear	White	2XD 014 564-801
	BST-Round, dark lens, especially for hidden use, 1 controller, 2 flasherheads, 2 grommets	ECE	Dark	Blue	available on request
	BST-Round, dark lens, especially for hidden use, 1 controller, 2 flasherheads, 2 grommets	SAE	Dark	Blue	available on request
	BST-Round, 1 controller, 2 flasherheads, 2 grommets	ECE	Clear	Blue / Amber	2XD 014 564-011
	BST-Round, 1 controller, 2 flasherheads, 2 grommets	ECE	Clear	Blue / Red	2XD 014 564-021
	BST-Round, 1 controller, 2 flasherheads, 2 grommets	ECE	Clear	Red / Amber	2XD 014 564-611

## ACCESSORIES



2 L-brackets

9XD 863 533-101

\*k-approval variant available on request

**HELLA GmbH & Co. KGaA,**

Rixbecker Straße 75

59552 Lippstadt /Germany

Tel. +49 2941 38-0

Fax +49 2941 38-71 33

info@hella.com

www.hella.com

© HELLA GmbH & Co. KGaA, Lippstadt

J01586/07.19

Printed in Germany

Subject to technical and price modifications.